

# HVV1012-250 High Voltage, High Ruggedness

*L-Band Avionics Pulsed Power Transistor*

*1025-1150 MHz, 10 $\mu$ s Pulse, 1% Duty Cycle*

*For Airborne DME, TCAS and IFF Applications*



## FEATURES

- Silicon MOSFET Technology
- Operation from 24V to 50V
- High Power Gain
- Extreme Ruggedness
- Internal Input and Output Matching
- Excellent Thermal Stability
- All Gold Bonding Scheme

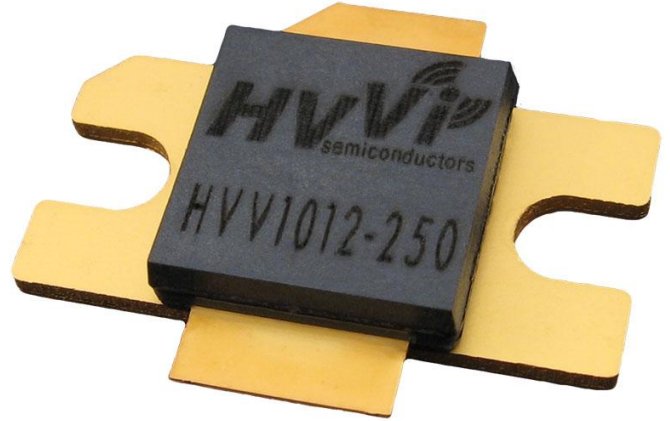

## TYPICAL PERFORMANCE

High voltage vertical technology is well suited for high power pulsed applications in the L-Band including Airborne DME, IFF, TCAS and Mode-S applications.

MODE	FREQUENCY (MHz)	VDD (V)	IDQ (mA)	Power (W)	GAIN (dB)	$\eta$ (%)	IRL (dB)	VSWR
Class AB	1150	50	100	250	19.5	48	-7	20:1

Table 1: Typical RF Performance in broadband test fixture at 25°C temperature with RF pulse conditions of pulse width = 10 $\mu$ s and pulse period = 1ms.

## DESCRIPTION

The high power HVV1012-250 device is an enhancement mode RF MOSFET power transistor designed for pulsed applications in the L-Band from 1025MHz to 1150MHz. The high voltage HVVFET™ technology produces over 250W of pulsed output power while offering high gain, high efficiency, and ease of matching with a 50 V supply. The vertical device structure assures high reliability and ruggedness as the device is specified to withstand a 20:1 VSWR at all phase angles under full rated output power.

## ORDERING INFORMATION

Device Part Number: HVV1012-250

Demo Kit Part Number: HVV1012-250-EK

Available through Richardson Electronics (<http://www.rell.com/>)

**HVV1012-250 High Voltage, High Ruggedness***L-Band Avionics Pulsed Power Transistor**1025-1150 MHz, 10 $\mu$ s Pulse, 1% Duty Cycle**For Airborne DME, TCAS and IFF Applications***ELECTRICAL CHARACTERISTICS**

Symbol	Parameter	Conditions	Min	Typical	Max	Unit
$V_{BR(DSS)}$	Drain-Source Breakdown	$V_{GS}=0V, I_D=5mA$	95	102	-	V
$I_{DSS}$	Drain Leakage Current	$V_{GS}=0V, V_{DS}=48V$	-	50	200	$\mu A$
$I_{GSS}$	Gate Leakage Current	$V_{GS}=5V, V_{DS}=0V$	-	1	5	$\mu A$
$G_P^1$	Power Gain	$F=1150MHz$	17.5	19.5	-	dB
$IRL^1$	Input Return Loss	$F=1150MHz$	-	-7	-4	dB
$\eta_D^1$	Drain Efficiency	$F=1150MHz$	46	48	-	%
$V_{GS(Q)}^2$	Gate Quiescent Voltage	$V_{DD}=50V, I_{DQ}=100mA$	1.1	1.45	1.8	V
$V_{TH}$	Threshold Voltage	$V_{DD}=5V, I_D=300\mu A$	0.7	1.2	1.7	V

**PULSE CHARACTERISTICS**

Symbol	Parameter	Conditions	Min	Typical	Max	Units
$t_r^1$	Rise Time	$F=1150MHz$	-	<40	50	ns
$t_f^1$	Fall Time	$F=1150MHz$	-	<15	50	ns
$PD^1$	Pulse Droop	$F=1150MHz$	-	0.25	0.5	dB

**THERMAL PERFORMANCE**

Symbol	Parameter	Max	Unit
$\theta_{JC}^1$	Thermal Resistance	0.10	$^{\circ}C/W$

**RUGGEDNESS PERFORMANCE**

Symbol	Parameter	Test Condition	Max	Units
$LMT^1$	Load Mismatch Tolerance	$F = 1150 MHz$	20:1	VSWR

The HVV1012-250 device is capable of withstanding an output load mismatch corresponding to a 20:1 VSWR at rated output power and nominal operating voltage across the frequency band of operation.

1.) NOTE: All parameters measured under pulsed conditions at 250W output power measured at the 10% point of the pulse with pulse width = 10 $\mu$ sec, duty cycle = 1% and  $V_{DD} = 50V$ ,  $I_{DQ} = 100mA$  in a broadband matched test fixture.

2.) NOTE: Amount of gate voltage required to attain nominal quiescent current.

# HVV1012-250 High Voltage, High Ruggedness

*L-Band Avionics Pulsed Power Transistor*

*1025-1150 MHz, 10µs Pulse, 1% Duty Cycle*

*For Airborne DME, TCAS and IFF Applications*

Typical Power Performance  
in a Broadband Matched Circuit

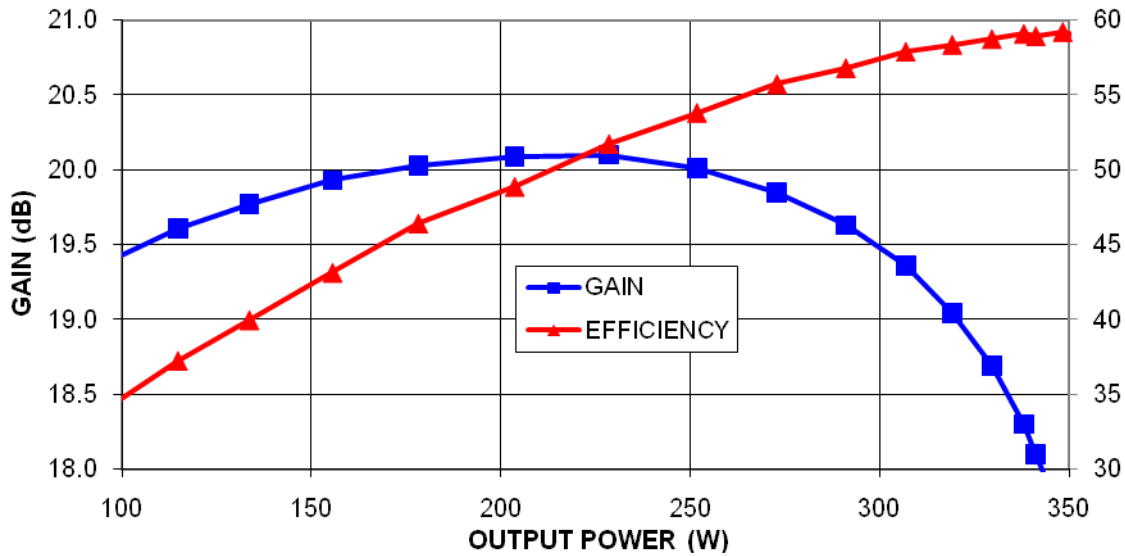

Typical device performance under Class AB mode of operation and RF pulse conditions of 10µs pulse width and 1% duty cycle with  $V_{DD} = 50V$  and  $I_{DQ} = 100mA$ . The device was measured at 1150MHz.

Typical Power Performance  
in a Broadband Matched Circuit

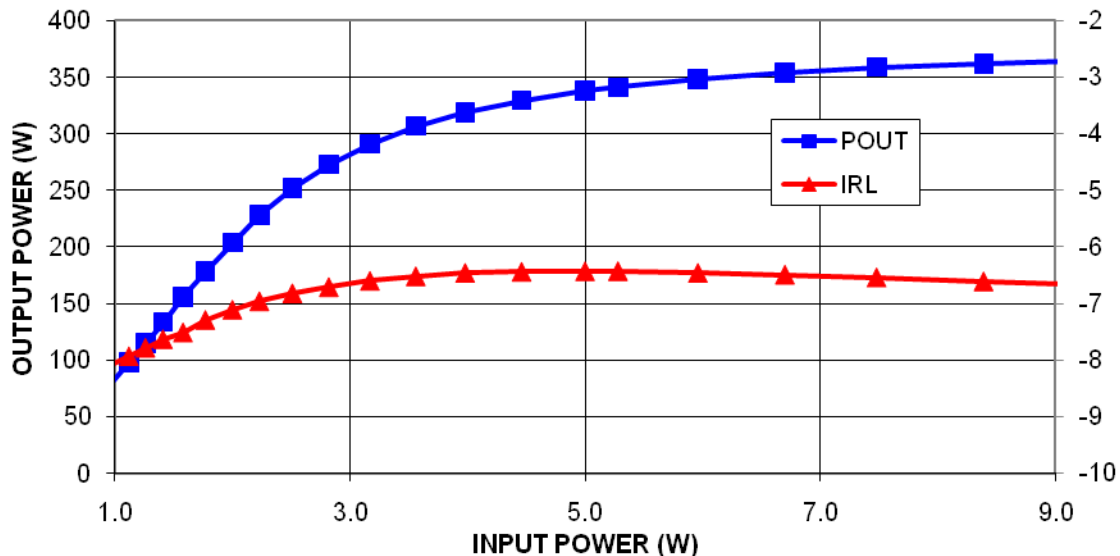

Typical device performance under Class AB mode of operation and RF pulse conditions of 10µs pulse width and 1% duty cycle with  $V_{DD} = 50V$  and  $I_{DQ} = 100mA$ . The device was measured at 1150MHz.

# HVV1012-250 High Voltage, High Ruggedness

*L-Band Avionics Pulsed Power Transistor*

*1025-1150 MHz, 10 $\mu$ s Pulse, 1% Duty Cycle*

*For Airborne DME, TCAS and IFF Applications*

**Typical Performance vs Frequency  
in a Broadband Matched Circuit**

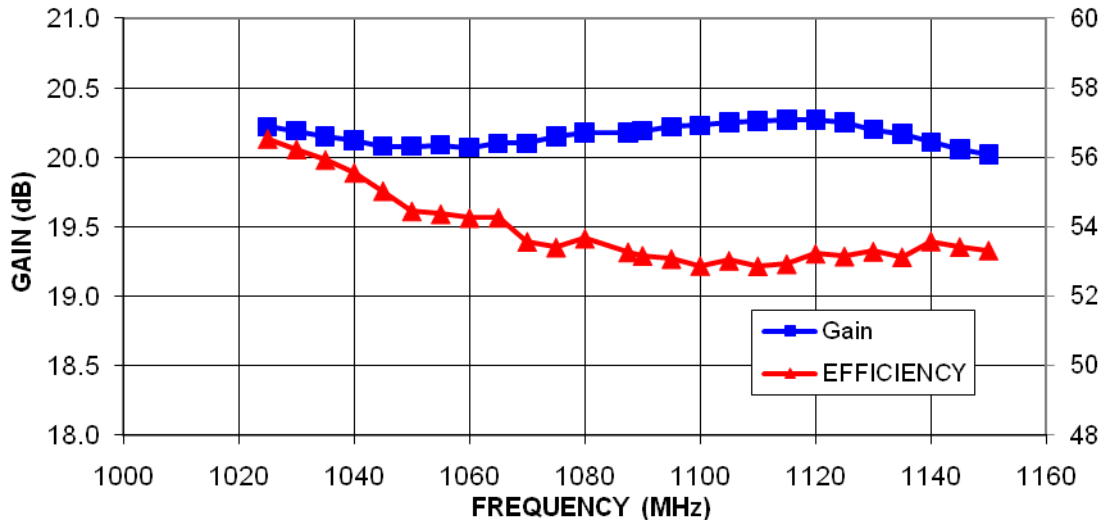

Typical device performance under Class AB mode of operation and RF pulse conditions of 10 $\mu$ s pulse width and 1% duty cycle with  $V_{DD} = 50V$  and  $I_{DQ} = 100mA$ . The device was measured at an output power of 250W.

**Typical Performance vs Frequency  
in a Broadband Matched Circuit**

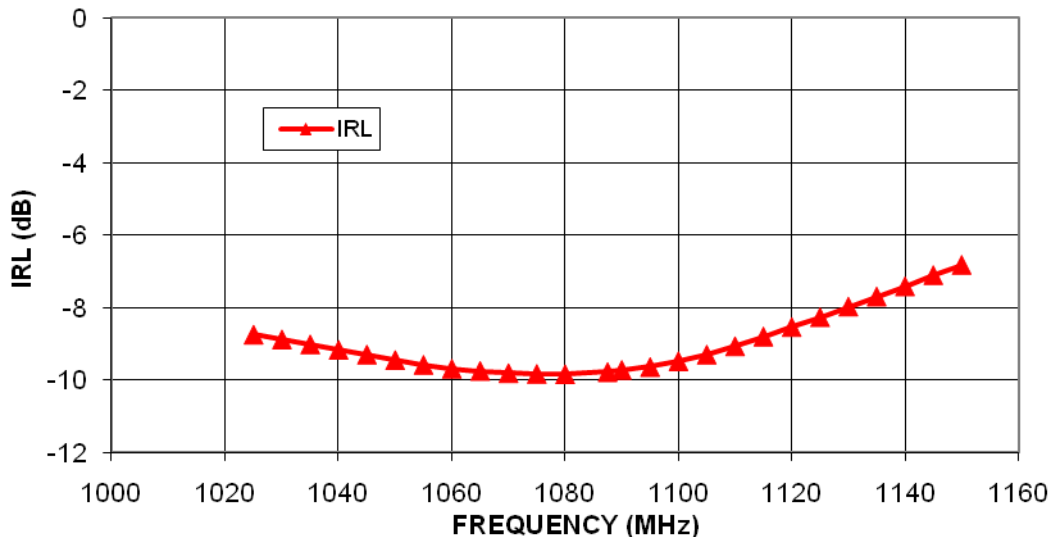

Typical device performance under Class AB mode of operation and RF pulse conditions of 10 $\mu$ s pulse width and 1% duty cycle with  $V_{DD} = 50V$  and  $I_{DQ} = 100mA$ . The device was measured at an output power of 250W.

# HVV1012-250 High Voltage, High Ruggedness

*L-Band Avionics Pulsed Power Transistor*

*1025-1150 MHz, 10µs Pulse, 1% Duty Cycle*

*For Airborne DME, TCAS and IFF Applications*

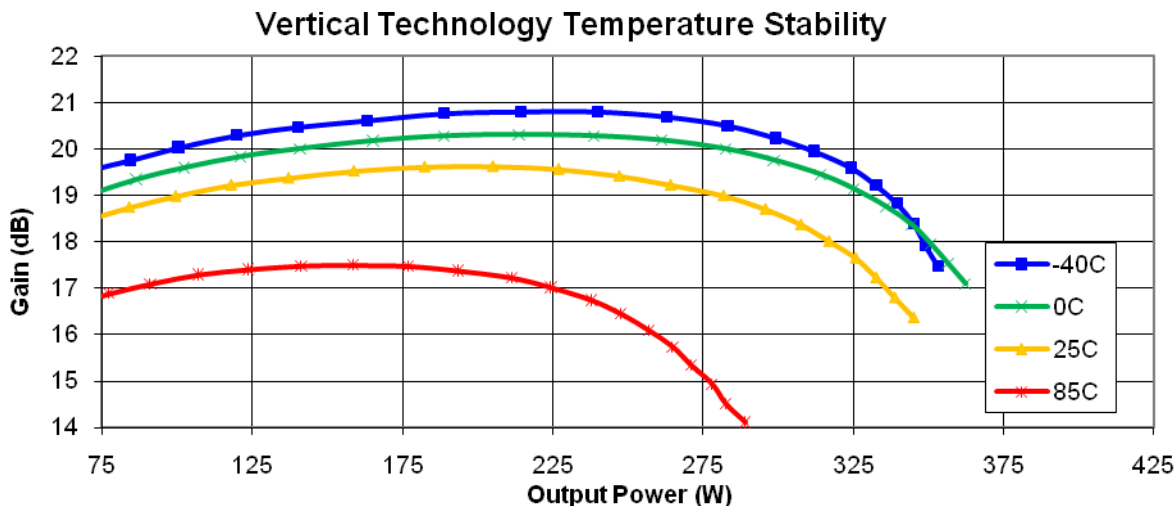

Typical device performance under Class AB mode of operation at 1150MHz and RF pulse conditions of 10µs pulse width and 1% duty cycle with  $V_{DD} = 50V$  and  $I_{DQ} = 100mA$ . The high voltage silicon vertical technology shows less than 1.5dB of power degradation over an extreme case temperature rise of 125°C.

Measured at P1dB Compression Point			
TEMP	Gain (dB)	Power (W)	Power (dBm)
-40C	19.8	320	55.1
0C	19.3	320	55.1
25C	18.6	300	54.8
85C	16.5	250	54.0

HVV1012-250 Performance over Temperature

# HVV1012-250 High Voltage, High Ruggedness

*L-Band Avionics Pulsed Power Transistor*

*1025-1150 MHz, 10µs Pulse, 1% Duty Cycle*

*For Airborne DME, TCAS and IFF Applications*

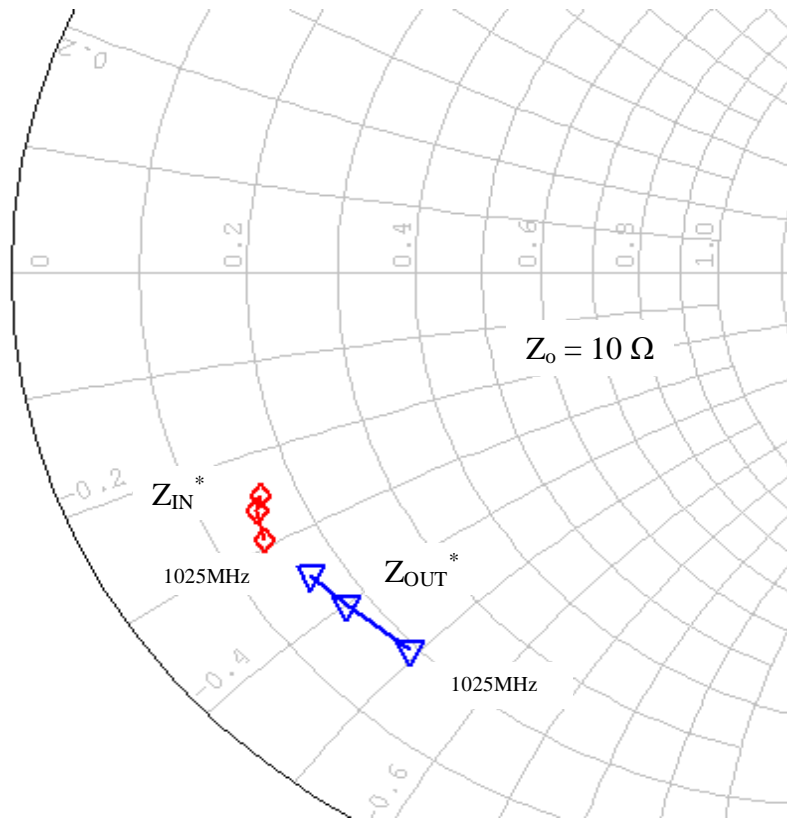

## Test Circuit Impedances

Frequency	Zin*(ohms)	Zout*(ohms)
1025MHz	1.46-j2.73	1.96-j4.67
1090MHz	1.58-j2.45	1.81-j3.99
1150MHz	1.67-j2.32	1.72-j3.51

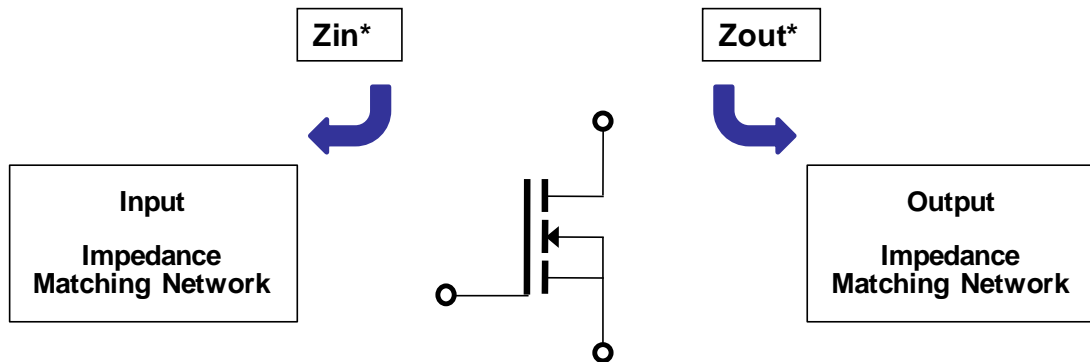

# HVV1012-250 High Voltage, High Ruggedness L-Band Avionics Pulsed Power Transistor 1025-1150 MHz, 10µs Pulse, 1% Duty Cycle For Airborne DME, TCAS and IFF Applications

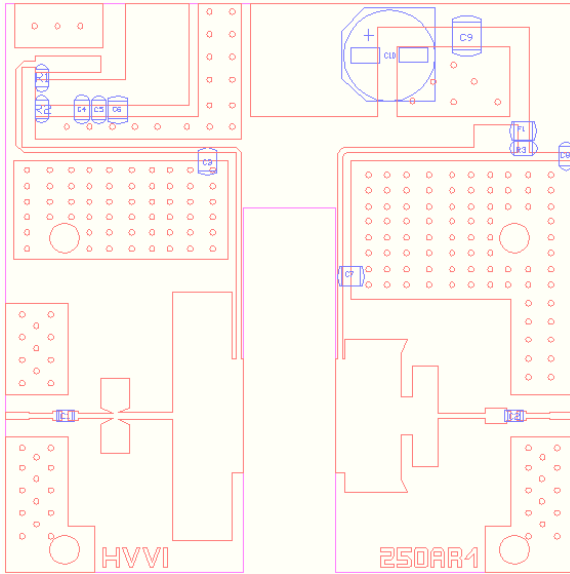

Demonstration Board Outline



Example of Circuit Fixture

Part	Description	Part Number	Manufacturer
C1, C2:	39 pF Johanson High Q 805 Chip Capacitor	251R15S390JV4E	Johanson
C3:	30 pF ATC 100B Chip Capacitor	100B300JP500X	ATC
C4:	1K pF 100V Chip Capacitor (X7R 1206)	C1206C102K1RACTU	Kemet
C5:	10K pF 100V Chip Capacitor (X7R 1206)	C1206C103K1RACTU	Kemet
C6:	10 uF 6.3V Tant cap	478-3134-1-ND	Digi Key
C7:	39 pF ATC 100B Chip Capacitor	100B390JP500X	ATC
C8:	1K pF 150V AVX (X7R 1210) Chip Capacitor	478-2666-1-ND	Digi Key
C9:	10uF 100V X7R Stacked SMD	445-4109-2-ND	Digi Key
C10:	200 uF 63V Elect FK SMD	PCE3484TR-ND	Digi Key
R1, R2:	10 Ohms Chip Resistor (1206)	ERJ8GEYJ100V	Panasonic
R3:	1.0 K Ohms Chip Resistor (1206)	ERJ8GEYJ102V	Panasonic
F1:	Fair-Rite Bead 43 SM Bead	2743019447	Fair-Rite
RF Connectors	Type "N" RF connectors	5919CC-TB-7	Coaxicom
DC Drain Conn	Connector Jack Banana Nylon Red	J151-ND	DIGI-KEY
DC Ground Conn	Connector Jack Banana Nylon Black	J152-ND	DIGI-KEY
DC Gate Conn.	Connector Jack Banana Nylon Green	J153-ND	DIGI-KEY
PCB Board	PCB: 25 mils thick, 10 Dielectric, 1 oz Copper		DS Electronics
Device Clamp	Cool Innovation Nylon Clamp Foot	FXT000204	Cool Innovation
Heat Sink	Cool Innovations Aluminum Heat Sink	3-252510RS3394 Rev C	Cool Innovation
S.S. Screws (4)	4-40 X 1/4 Stainless Steel Socket Hex Head	P242393	Copper State Bolt
Alloy Screws (4)	4-40 X 1/2 Alloy Socket Cap screw Hex H	SCAS-0440-08C	Small Parts Inc
Metal Washer (6)	#4 Washer Zinc PLTD Steel Lock	ZSLW-004-M	Small Parts Inc
Alloy Screws (2)	4-40 X 3/4 Alloy Socket Cap Screw Head	SCAS-0440-12M	Small Parts Inc

HVV1012-250 Demonstration Circuit Board Bill of Materials

# HVV1012-250 High Voltage, High Ruggedness L-Band Avionics Pulsed Power Transistor 1025-1150 MHz, 10µs Pulse, 1% Duty Cycle For Airborne DME, TCAS and IFF Applications

## PACKAGE DIMENSIONS

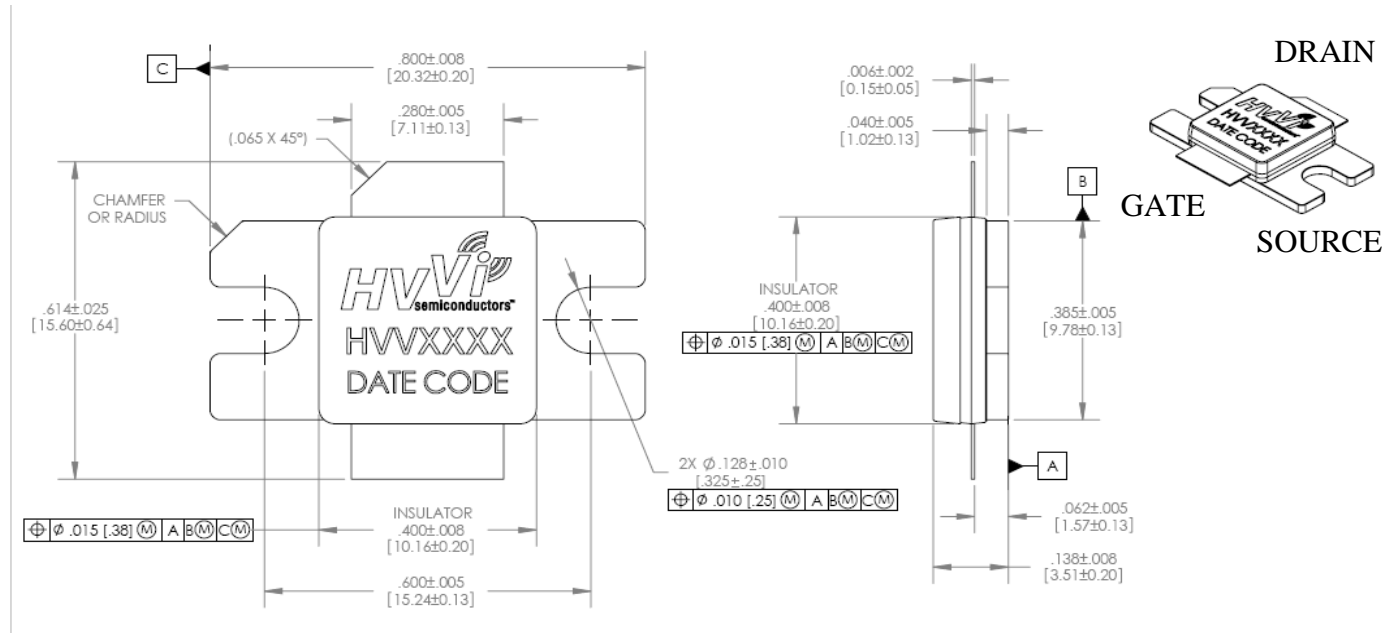

Note: Drawing is not actual size.

HVVi Semiconductors, Inc. (HVVi) reserves the right to make changes to information published in this document at any time and without notice. This document supersedes and replaces all information supplied prior to the publication hereof. Information in this document is believed to be accurate and reliable. However, HVVi does not give any representations or warranties, either expressed or implied, as to the accuracy or completeness of such information and shall have no liability for the consequences of use of such information. No license, either expressed or implied, is conveyed under any HVVi intellectual property rights, including any patent rights. The HVVi name and logo are trademarks of HVVi Semiconductors, Inc.